

# DG-Block

## DIGITAL CONTROLLER

# MEROBEL

## Torque & Tension

- > Compact and complete solution
- > Easy set up with software interface
- > Multi spindle design



DG-Block is the new benchmark in closed loop **digital controllers** for all industries using equipment managing a large number of wires, cables, fibers or narrow webs.

### DG-Block

DG-Block is a true turnkey solution relying on a very intuitive programming system, the user friendly computer software (DG-BlockSoft).

Each block is designed to make a torque & tension control solution with universal amplifier – advanced regulation – brake power supply & analog drive output

Shared process instructions from one leader device to several follower devices, without any extra wiring.

### DIMENSIONS

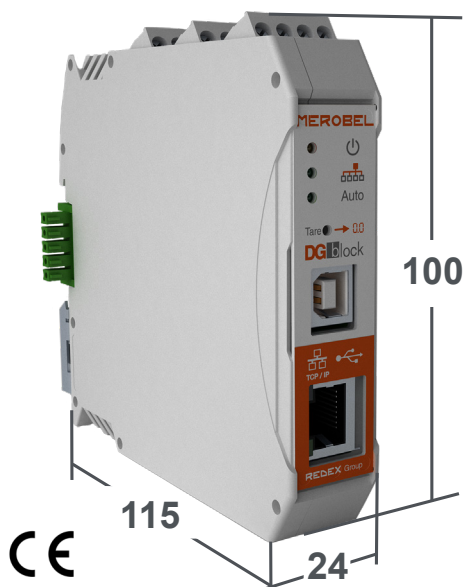

### ADVANCED FEATURES OF REGULATION

- > Built-in **precision amplifier** for 1 or 2 load cells
- > P.I.D **regulation** algorithm
- > Open + closed loop modes included
- > **Direct power supply** for e-brake
- > Very easy set-up with the PC software (Windows)
- > Automation communication : MODBUS TCP/IP
- + > Specifically designed for Mutli spindle applications

### TECHNICAL FEATURES

Part number	#	ME134330-00
Power supply	[V DC]	24 → 35
Max power consumption	[VA]	70
Input measure	[V DC]	1 mV → 10 V
Input set point	[V DC]	0 → 10
Input logics	[V DC]	5 → 24
Output A01 & A02	[V DC]	-10 → +10
Output C1-C2 max current	[A]	1.5
Ambient temperature	[ °C ]	0 → 40
Weight	g	150

# DG-Block

## DIGITAL CONTROLLER

# MEROBEL

Torque & Tension

### SETTINGS

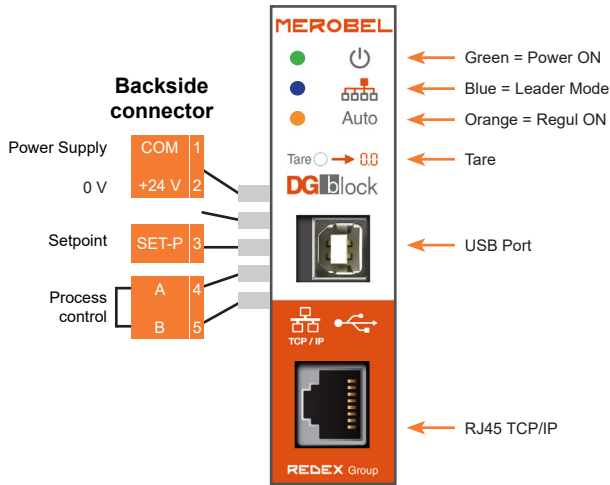

### PRINCIPLE

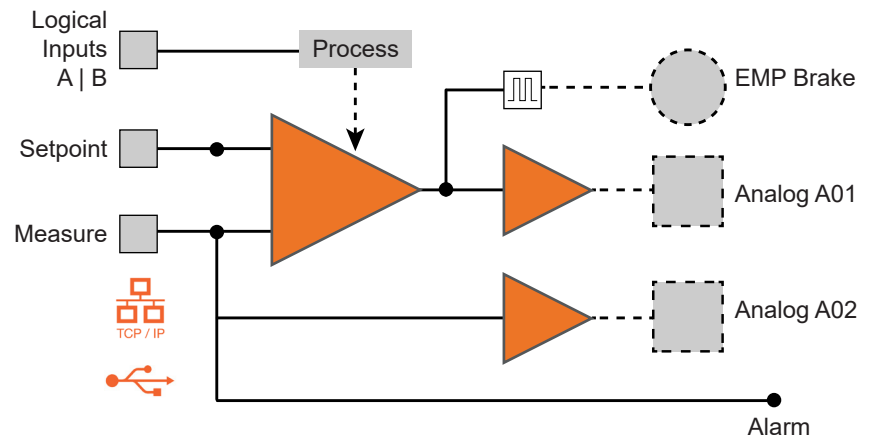

### SOFTWARE



Simple interface with all parameter settings displayed in a unique window

Scope function for easy data readout

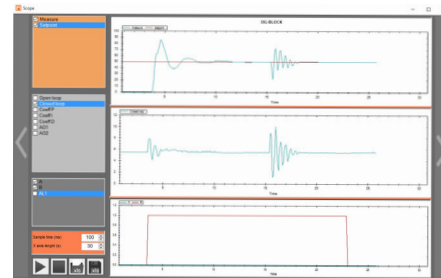

All parameters can also be addressed by modbus TCP/IP with external PLC or HMI.

### CONNECTIONS

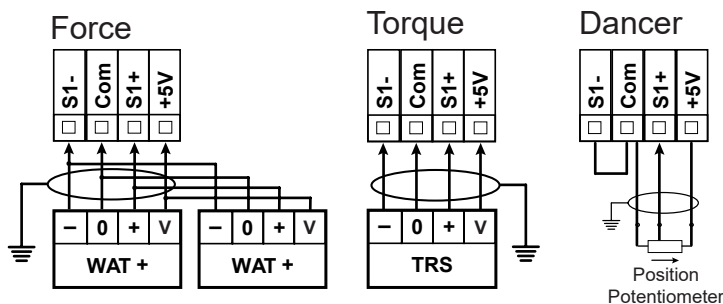
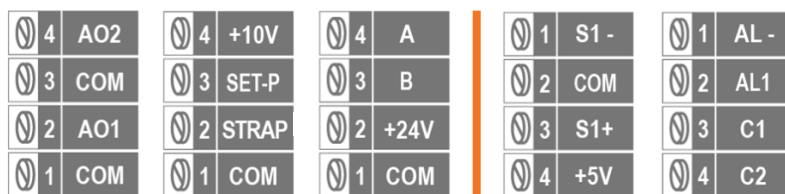

Com	0 V
Strap	Strap to COM to enable leader mode
Set-P	Set point (0-10V or Pot.)
+10V	10V supply
S1-/S1+	Signal (-) / Signal (+)
+5V	Sensor supply
+24V	+24V DC - main supply
C1	Power output direct supply1
C2	Power output direct supply2
AL-	Output logic reference
AL1	Logic output1
A	Logic input 1
B	Logic input 2
AO1	Analog output 1 (-10 → +10V)
AO2	Measure readout (-10 → +10V)