

FMS-webMASTER BKS 015 Web Guide

Sophisticated design

Cost effective web guiding solution

Integrated electronic unit

No additional wiring required

No programming required

Easy to setup, straightforward use

Compact and robust construction

Reliable and maintenance free operation



● FMS-webMASTER BKS 015

With any type of narrow material processing, it is vital to maintain the web in the correct lateral position. Whether printing labels, gluing packages, laminating layers, or applying isolation layers to a wire, exact material position is most important to the production process. Often this is done with stationary mechanical „guides“ which can damage the material edges. The ultra-compact web guide BKS 015 provides enhanced material control for increased line speeds and improved quality. The innovative, cost-conscious design provides the ideal solution for both existing and new narrow web production lines.

● Functional Description

Guiding control modes include Edge Left, Edge Right, and Center Guiding (using two sensors). The powerful stepper motor and ball screw spindle offers both high precision and a fast, accurate response. The electronic control unit is integrated into the steering frame, while the operator interface panel can be provided on either side of the frame and oriented in any of 90° increments to best suit the application. These features make the BKS 015 Web Guide very easy to install and operate. The BKS 015 Web Guide is available with roller widths of 100 to 250 mm, and is compatible with the full line of ultrasonic and optical material sensors available from FMS.

FMS-webMASTER BKS 015 • Dimensions in mm

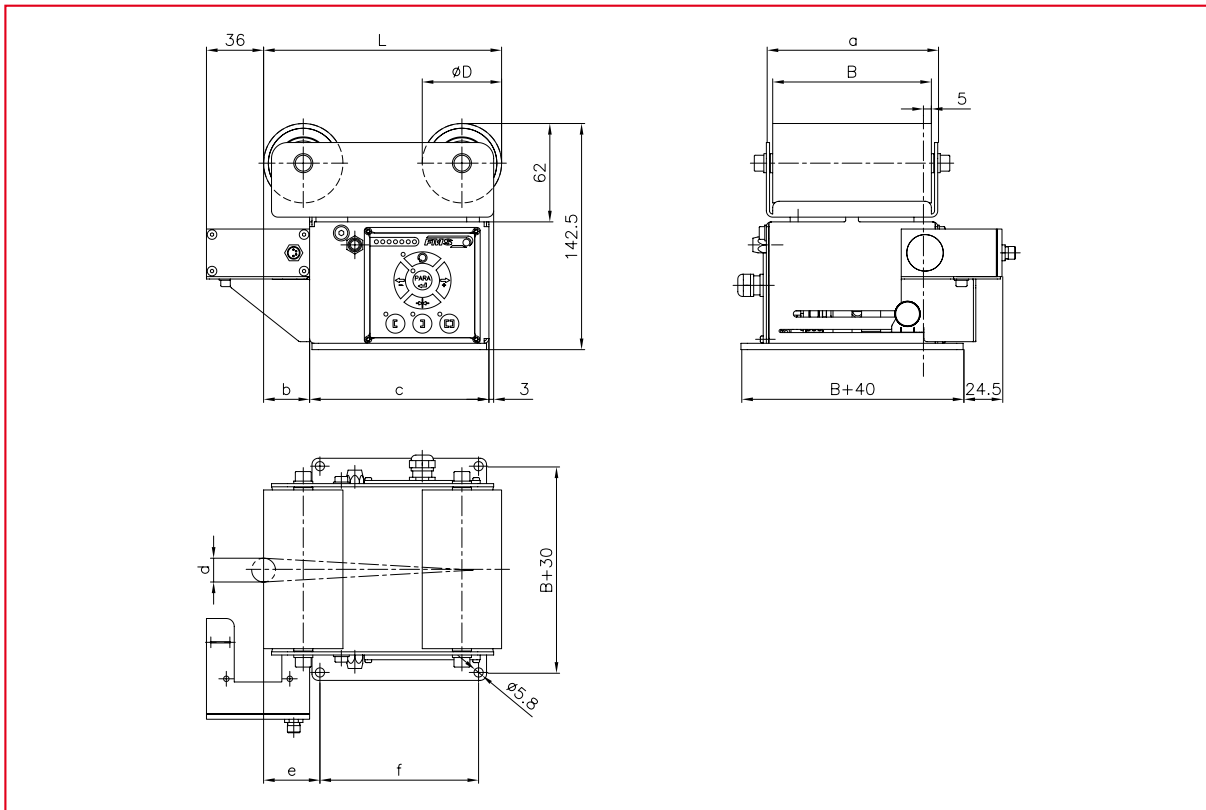

FMS-webMASTER BKS 015 • Dimensions in mm

Web guide Type	Roller width B	Frame length L	Roller dia. D	a	b	c	d	e	f
BKS 015.100.155.50.D	100	155	50	108	34	113	15	40.5	100
BKS 015.200.155.50.D	200	155	50	209	34	113	15	40.5	100
BKS 015.250.180.50.D	250	180	50	259	34	138	18	40.5	125

FMS-webMASTER BKS 015 • Technical specification

Steering offset	± 7.5 or 9 mm (for B = 250 mm)
Adjusting speed	18 mm/s
Drive	Stepper motor, spindle, backlash free nut
Sensors	Ultrasonic and optical
Power supply	24 VDC (18...30 V) / max. 1.5 A Galvanically isolated
Temperature range	- 10...60 °C [14...140 °F]
Protection class	IP 30

**Order code (Example):
FMS-webMASTER BKS 015**

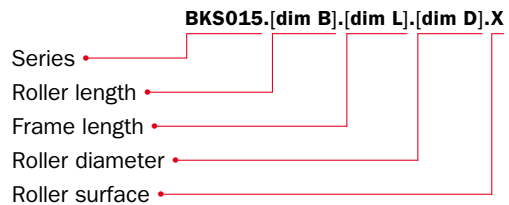

Order code example: BKS 015.200.155.50.D

World Headquarters:

FMS Force Measuring Systems AG
 Aspstrasse 6
 8154 Oberglatt (Switzerland)
 Phone + 41 44 852 80 80
 Fax + 41 44 850 60 06
 info@fms-technology.com

FMS USA, Inc.
 2155 Stonington Avenue
 Suite 119
 Hoffman Estates, IL 60169
 Phone + 1 847 519 4400
 Fax + 1 847 519 4401
 fmsusa@fms-technology.com

FMS UK
 Highfield, Atch Lench Road
 Church Lench
 Evesham WR 11 4UG
 Phone + 44 1386 871023
 Fax + 44 1386 871021
 fmsuk@fms-technology.com

FMS Italy
 Via Baranzate 67
 20026 Novate Milanese
 Phone + 39 02 39487035
 Fax + 39 02 39487035
 fmsit@fms-technology.com